

REENVIOS DE ÁNGULO

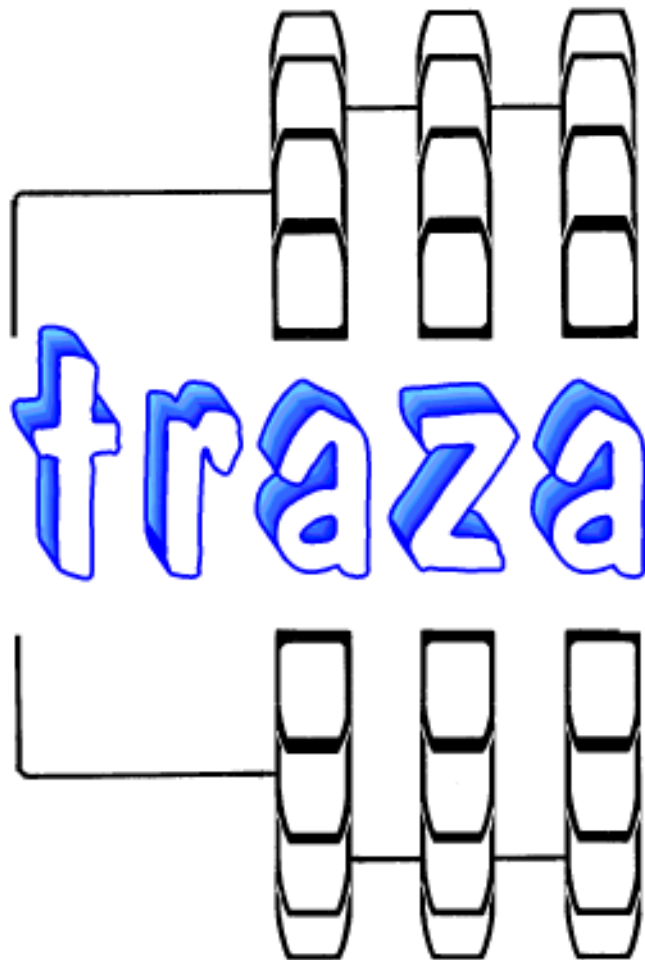

Transmisiones Zaragoza, S.L.

Isla de Menorca, s/nr. - Edificio Estrella, Local nr. 2

50014 - Zaragoza

Tfno. (976) 47 01 02 (8 líneas) - Fax (976) 47 32 20

E-Mail: traza@trazasl.com

www.trazasl.com

Transmisiones Zaragoza, S.L.

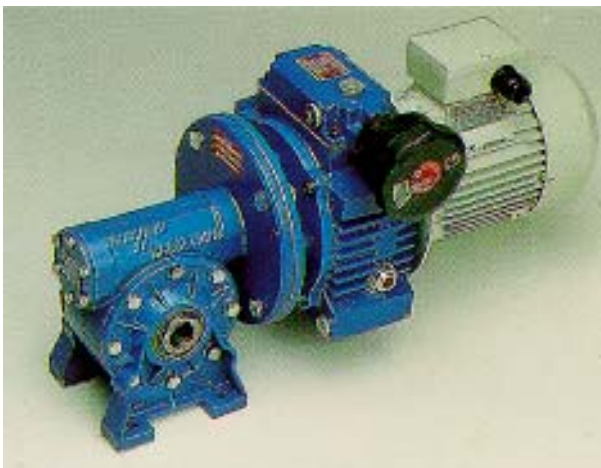

Indice

R

REENVIOS

REENVIOS DE ANGULO

Selección, 10, 11

Serie ligera, 5

Serie pesada, 6, 7

REENVIOS DE ANGULO CON ENGRANAJES CONICOS HELICOIDALES

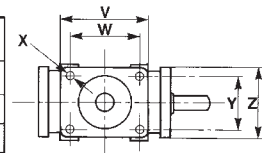
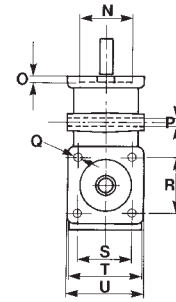
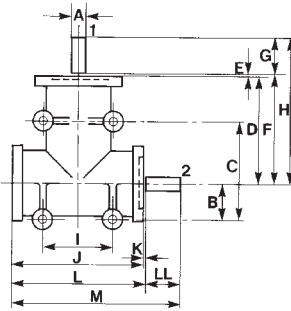

MEDIDAS	1 SALIDA				2 SALIDAS				EJE HUECO 2 SALIDAS		
	2002	2011	2030	2032	2002	2008	2031	2033	2012	2028	
A	mm	8h7	14h7	19	24	8h7	14h7	19	24	14h7	19h7
B	mm	20	32	43	43	20	32	43	43	32	43
C	mm	55	95	86	86	55	95	86	86	95	86
D	mm	60	90	140	140	60	90	140	140	90	140
E	mm	1	1	1	1	1	1	1	1	1	1
F	mm	61	91	141	141	61	91	141	141	91	141
G	mm	20	30	40	50	20	30	40	50	30	40
H	mm	81	121	181	191	81	121	181	191	121	181
I	mm	40	60	86	86	40	60	86	86	60	86
J	mm	75	110	150	150	75	110	150	150	110	150
K	mm	1	1	1	1	1+1	1+1	1+1	1+1	1+1	1+1
L	mm	76	111	151	151	77	112	152	152	112	152
LL	mm	20	30	40	50	20+20	30+30	40+40	50+50	1+1	1+1
M	mm	96	141	191	201	117	172	232	252	112	152
N	mm	30h7	47h7	62	62	30h7	47h7	62	62	47h7	62
O	mm	2,5	3	5	5	2,5	3	5	5	3	5
P	mm	5	8,5	11	11	5	8,5	11	11	8,5	11
Q	mm	M4	M8	M10	M10	M4	M8	M10	M10	M8	M10
R	mm	30	-	60	60	30	-	60	60	-	60
S	mm	30	-	60	60	30	-	60	60	-	60
T	mm	42	-	-	-	42	-	-	-	-	-
U	mm	43	70	86	86	43	70	86	86	70	86
V	mm	50	-	-	-	50	-	-	-	-	-
W	mm	40	-	80	80	40	-	80	80	-	80
X	mm	5	-	10,5	10,5	5	-	10,5	10,5	-	10,5
Y	mm	30	-	60	60	30	-	60	60	-	60
Z	mm	42	-	-	-	42	-	-	-	-	-
CV a 1.400 rpm entrada eje 1	Relación 1:1	0,58	2,5	7,5	10	0,58	2,5	7,5	10	2,5	7
	1:2	0,14	1	2,5	4	0,14	1	2,5	4	0,68	2,5
	1:3	-	0,5	1,25	2	-	0,5	1,25	2	0,34	1,25
Par de salida Eje 2/Eje 2 y 3 mKg	1:1	0,30	1,33	3,67	5	0,15+0,15	0,6+0,6	1,84+1,84	2,55+2,55	1,20	3,67
	1:2	0,15	1,02	2,55	4	0,08+0,08	0,5+0,5	1,28+1,28	2+2	0,65	2,55
	1:3	-	0,767	1,84	2,85	-	0,38+0,38	0,92+0,92	1,42+1,42	0,45	1,84
Peso	Kg	0,500	2,00	4,400	4,400	0,500	2,00	4,400	4,400	2,00	4,800

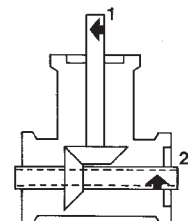
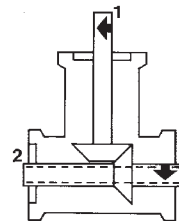
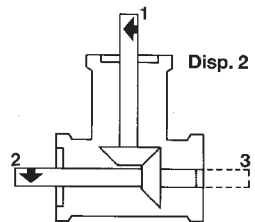
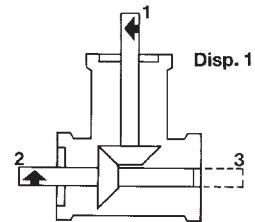

NOTA: Para REENVIOS de 3 salidas e inversores, rogamos consulten

REENVIOS DE ANGULO SERIE PESADA

PROGRAMA DE FABRICACION

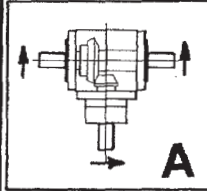
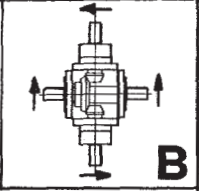
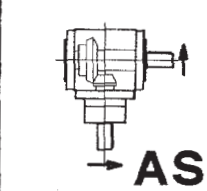
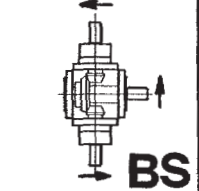
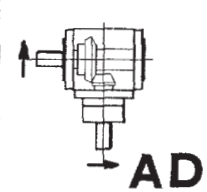
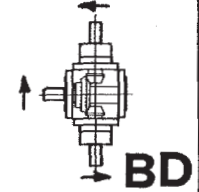
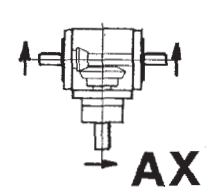
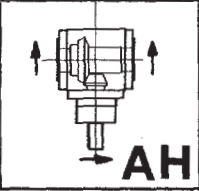
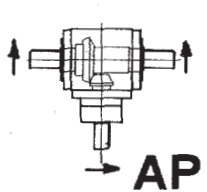
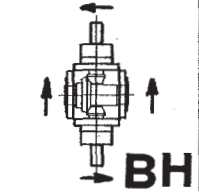
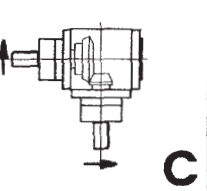
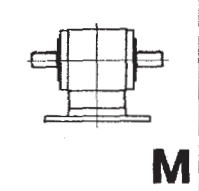
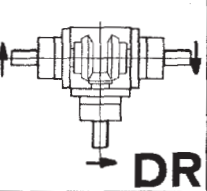
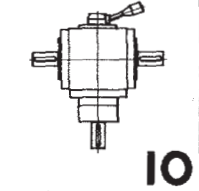
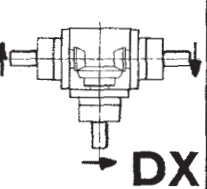
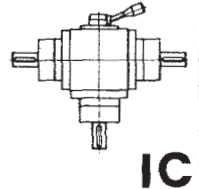
	DOBLE SALIDA SOLIDARIA relaciones 1:1 a 5:1		EJE SOLIDARIO LENTO dos salidas rápidas contrarrotantes relaciones 1:1 a 5:1
	SALIDA SIMPLE sentido de giro relaciones 1:1 a 5:1		EJE SIMPLE LENTO dos salidas rápidas contrarrotantes relaciones 1:1 a 5:1
	SALIDA SIMPLE sentido de giro relaciones 1:1 a 5:1		EJE SIMPLE LENTO dos salidas rápidas contrarrotantes relaciones 1:1 a 5:1
	MULTIPLICADOR doble salida relaciones 1:1,5 y 1:2		SALIDA EJE HUECO PASANTE relaciones 1:1 a 5:1
	DOBLE SALIDA eje salida reforzado relaciones 1:1 a 5:1		EJE HUECO LENTO dos salidas rápidas contrarrotantes relaciones 1:1 a 5:1
	MULTIPLICADOR REDUCTOR relaciones 1:1 a 5:1		PREPARADO MOTOR eje de entrada hueco salida doble solidaria relaciones 1:1 a 5:1
	REDUCTOR salidas contrarrotantes relaciones 1:1 a 5:1		INVERSOR DE GIRO DESCONECTOR relaciones 1:1 a 2:1
	MULTIPLICADOR salidas contrarrotantes relaciones 1:1 a 5:1		INVERSOR DE GIRO COAXIAL relación única 1:1

REENVIOS DE ANGULO SERIE PESADA CON 1 o 2 EJES DE SALIDA

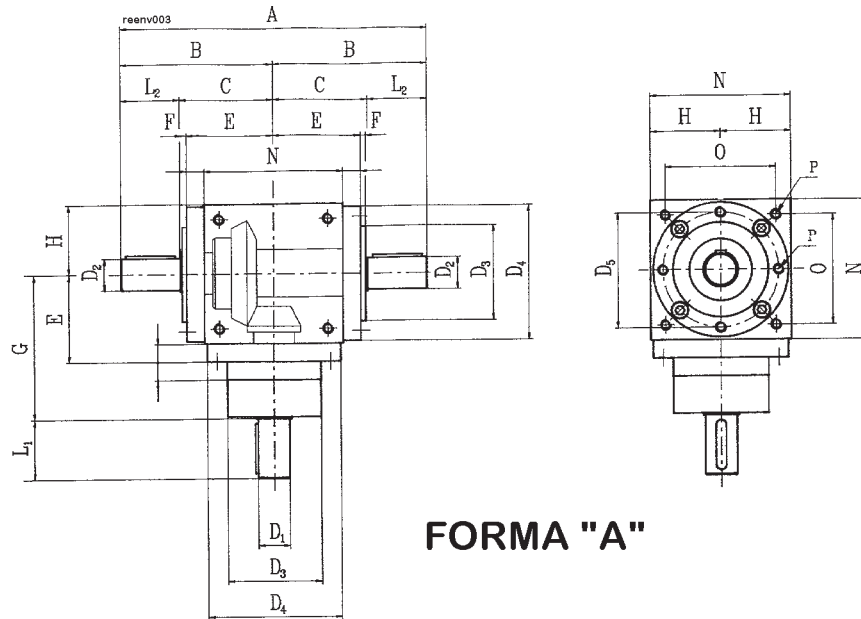

FORMA "A"

MEDIDAS (en milímetros)

TIPO	RELACION	A	B	C	D ₁	D ₂	D ₃	D ₄	D ₅	E	F	G	H	L ₁	L ₂	N	O	P
BG12	1 2 3 4 5	144	72	46	12	12	44	/	54	42	2	74	32.5	26	26	65	45	M6
BG19	1 2 3	210	105	65	19	19	60	86	72	59	4	100	45	40	40	90	70	M6
	4 5				14									30				
BG24	1 2 3	260	130	80	24	24	70	105	88	73	5	115	55	50	50	110	88	M8
	4 5				19									40				
BG32	1 2 3	310	155	95	32	32	95	135	115	88	5	145	70	60	60	140	110	M10
	4 5				24									50				
BG38	1 2 3	360	180	110	38	38	120	165	145	103	5	170	85	70	70	170	136	M12
	4 5				28									60				
BG42	1 2 3	410	205	125	42	42	135	190	165	118	5	195	100	80	80	200	155	M12
	4 5				32									60				
BG55	1 2 3	520	260	150	55	55	170	230	205	143	5	245	120	110	110	240	190	M14
	4 5				42									80				
BG75	1 2 3	750	375	225	75	75	/	300	/	218	5	350	165	150	150	330	248	M16
	4 5				55									110				

REENVIOS DE ANGULO SERIE PESADA CON EJE HUECO DE SALIDA

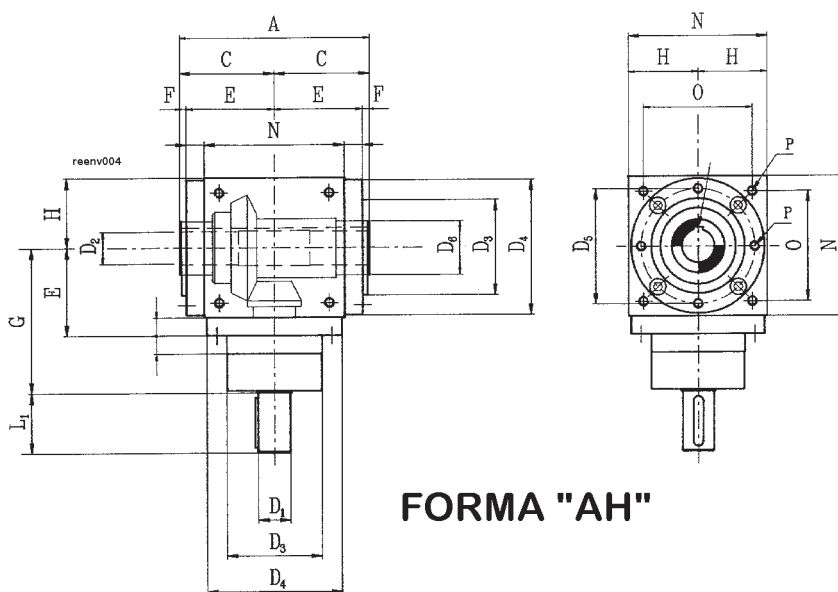

FORMA "AH"

MEDIDAS (en milímetros)

TIPO	RELACION	A	C	D ₁	D ₂	D ₃	D ₄	D ₅	D ₆	E	F	G	H	L ₁	N	O	P
BG12																	
BG19	1 2 3	130	65	19	19	60	86	72	30	59	4	100	45	40	90	70	M6
	4 5			14										30			
BG24	1 2 3	160	80	24	24	70	105	88	35	73	5	115	55	50	110	88	M8
	4 5			19										40			
BG32	1 2 3	190	95	32	32	95	135	115	50	88	5	145	70	60	140	110	M10
	4 5			24										50			
BG38	1 2 3	220	110	38	38	120	165	145	60	103	5	170	85	70	170	136	M12
	4 5			28										60			
BG42	1 2 3	250	125	42	42	135	190	165	60	118	5	195	100	80	200	155	M12
	4 5			32										60			
BG55	1 2 3	300	150	55	55	170	230	205	75	143	5	245	120	110	240	190	M14
	4 5			42										80			
BG75	1 2 3	450	225	75	75	/	300	/	120	218	5	350	165	150	330	248	M16
	4 5			55										110			

REENVIOS DE ANGULO SERIE PESADA CON 3 EJES DE SALIDA

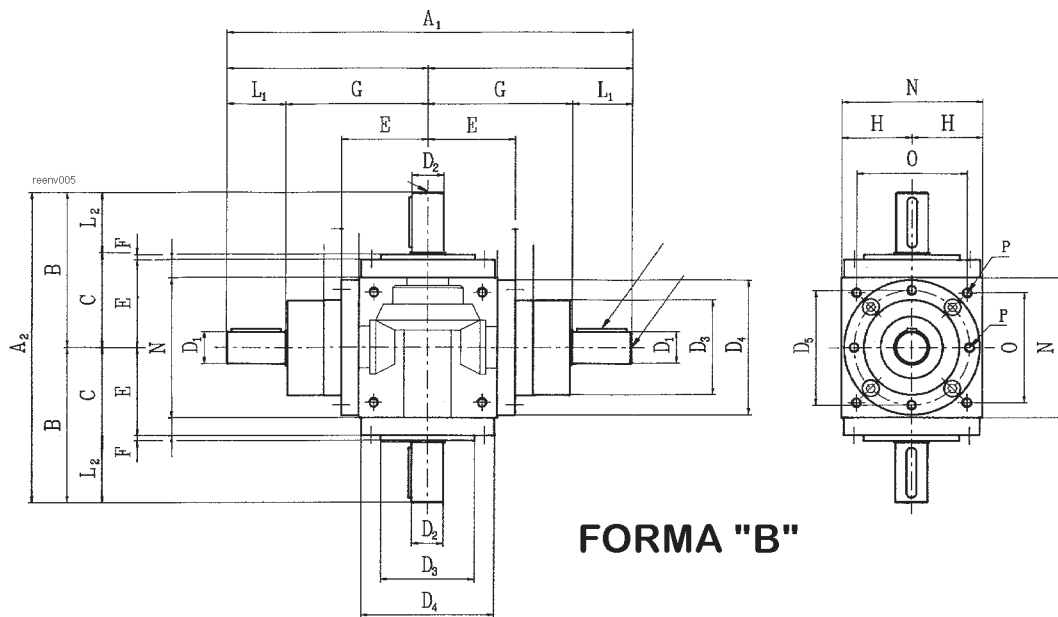

FORMA "B"

MEDIDAS (en milímetros)

TIPO	RELACION	A ₁	A ₂	B	C	D ₁	D ₂	D ₃	D ₄	D ₅	E	F	G	H	L ₁	L ₂	N	O	P
BG12	1 2 3	200	144	72	46	12	12	44	/	54	42	2	74	32.5	26	26	65	45	M6
BG19	1 2 3	280	210	105	65	19	19	60	86	72	59	4	100	45	40	40	90	70	M6
	4 5	280				14									30				
BG24	1 2 3	330	260	130	80	24	24	70	105	88	73	5	115	55	50	50	110	88	M8
	4 5	310				19									40				
BG32	1 2 3	410	310	155	95	32	32	95	135	115	88	5	145	70	60	60	140	110	M10
	4 5	390				24									50				
BG38	1 2 3	480	360	180	110	38	38	120	165	145	103	5	170	85	70	70	170	136	M12
	4 5	460				28									60				
BG42	1 2 3	550	410	205	125	42	42	135	190	165	118	5	195	100	80	80	200	155	M12
	4 5	510				32									60				
BG55	1 2 3	710	520	260	150	55	55	170	230	205	143	5	245	120	110	110	240	190	M14
	4 5	650				42									80				
BG75	1 2 3	1000	750	375	225	75	75	/	300	/	218	5	350	165	150	150	330	248	M16
	4 5	920				55									110				

TABLA DE SELECCION REENVIOS DE ANGULO SERIE PESADA

UNIT SIZE	input rpm	RATIO 1:1		RATIO 1:1.5		RATIO 1:2		RATIO 1:3		RATIO 1:4		RATIO 1:5	
		Power input kW	Torque output Nm	Power input kW	Torque output Nm	Power input kW	Torque output Nm	Power input kW	Torque output Nm	Power input kW	Torque output Nm	Power input kW	Torque output Nm
BG12	2800	3.08	10.1	--	--	1.61	10.6	0.59	5.8	--	--	--	--
	2000	2.30	10.6	--	--	1.19	10.9	0.46	6.3	--	--	--	--
	1500	1.88	11.5	--	--	0.94	11.5	0.38	6.9	--	--	--	--
	1000	1.36	12.5	--	--	0.68	12.5	0.27	7.5	--	--	--	--
	800	1.17	13.4	--	--	0.59	13.4	0.23	8.1	--	--	--	--
	600	0.94	14.4	--	--	0.47	14.4	0.19	8.6	--	--	--	--
	400	0.67	15.4	--	--	0.34	15.4	0.13	8.9	--	--	--	--
	100	0.18	16.8	--	--	0.09	16.7	0.03	9.4	--	--	--	--
	50	0.10	18.2	--	--	0.05	18.2	0.02	9.8	--	--	--	--
	10	0.02	19.2	--	--	0.01	19.2	0.01	10.1	--	--	--	--
BG19	2800	16.27	53.3	7.36	36.1	6.51	42.6	2.4	23.6	2.07	27.1	1.32	21.6
	2000	11.94	54.7	5.38	37	4.73	43.4	1.75	24	1.5	27.5	0.96	21.9
	1500	9.17	56.1	4.12	37.7	3.6	44	1.34	24.5	1.13	27.6	0.72	22.1
	1000	6.26	57.4	2.81	38.6	2.46	45.1	0.91	24.9	0.77	28.3	0.49	22.5
	800	5.07	58.1	2.27	39	1.99	45.7	0.73	25.1	0.62	28.5	0.39	22.6
	600	3.85	58.8	1.73	39.6	1.51	46.1	0.55	25.4	0.47	28.8	0.3	22.8
	400	2.62	60	1.16	40	1.02	46.7	0.37	25.8	0.32	29	0.2	22.9
	100	0.69	62.9	0.3	41.5	0.27	46.8	0.10	26.4	0.08	29.7	0.05	23.4
	50	0.35	63.7	0.15	42	0.13	49.3	0.05	26.6	0.04	29.9	0.03	23.6
	10	0.07	64.6	0.03	42.5	0.03	49.7	0.01	26.8	0.01	30.2	0.01	23.8
BG24	2800	17.88	58.6	12.17	59.8	8.15	53.4	3.52	34.6	3.9	51.1	2.67	43.7
	2000	13.38	61.3	8.88	61.1	5.99	54.9	2.58	35.4	2.84	52	2.01	46.1
	1500	10.37	63.4	6.79	62.2	4.55	55.7	1.96	36	2.16	52.8	1.53	46.8
	1000	7.19	66	4.65	63.9	3.09	56.6	1.33	36.6	1.47	53.8	1.04	47.5
	800	5.86	67.2	3.75	64.5	2.5	57.2	1.08	37.2	1.18	54.1	0.84	48
	600	4.51	68.9	2.86	65.7	1.89	57.8	0.82	37.4	0.9	54.7	0.65	49.4
	400	3.08	70.6	1.94	66.7	1.28	58.6	0.55	38	0.6	55.3	0.44	49.9
	100	0.82	75.3	0.5	69.1	0.32	58.9	0.14	38.9	0.15	56.1	0.11	51.4
	50	0.42	77	0.25	70	0.16	59.1	0.07	39	0.08	57	0.06	51.8
	10	0.09	79.5	0.05	71.1	0.03	59.5	0.01	39.2	0.02	57.6	0.01	52.8
BG32	2800	40.8	133.4	23.5	115.2	15.5	101.8	7.33	72	5.42	71	3.52	57.6
	2000	30.4	139.2	17.6	121	11.5	105.6	5.76	79.2	4.14	75.8	2.64	60.5
	1500	23.6	144	13.7	125.3	8.8	107.5	4.4	80.6	3.14	76.8	2.01	61.4
	1000	16.3	149.8	9.4	129.6	6	109.4	2.98	82.1	2.12	77.8	1.36	62.4
	800	13.3	152.6	7.8	133.9	4.9	111.4	2.43	83.5	1.72	78.7	1.11	63.4
	600	10.2	156.5	6	136.8	3.7	113.3	1.85	85	1.3	79.7	0.85	64.8
	400	7	160.3	4.1	141.1	2.5	115.2	1.26	86.4	0.88	80.6	0.57	65.8
	100	1.9	170.9	1	144	0.6	119	0.32	89.3	0.23	84.5	0.15	67.2
	50	0.9	174.7	0.5	146.9	0.3	122.9	0.16	90.7	0.12	86.4	0.07	68.2
	10	0.2	180.5	0.1	149.8	0.1	124.8	0.03	92.2	0.02	88.3	0.02	69.1
BG38	2800	87.2	285.6	57.7	273.5	29.9	196	15.1	148	12.3	161	9.9	162
	2000	64.1	294	41	282	22	201	11	152	9	164	7.2	165.5
	1500	49.4	302	31.4	288	16.9	206	8.4	154	6.8	167	5.5	168.5
	1000	33.8	310	21.4	293.8	11.6	212	5.76	158	4.6	170	3.7	171
	800	27.6	316.5	17.4	300	9.4	215	4.66	160	3.7	171	3	173
	600	21.1	323	13.3	305	7.1	218	3.55	162.5	2.8	173.5	2.3	175
	400	14.5	331	9	311	4.8	222	2.4	165	1.9	176.5	1.5	176.5
	100	3.8	349	2.4	325.5	1.3	231	0.62	170.5	0.5	182	0.4	182
	50	1.9	355.5	1.2	332.5	0.6	234	0.31	172	0.25	183.5	0.2	184
	10	0.4	367	0.2	340	0.13	239	0.06	175	0.05	186	0.04	186

TABLA DE SELECCION REENVIOS DE ANGULO SERIE PESADA

UNIT SIZE	input rpm	RATIO 1:1		RATIO 1:1.5		RATIO 1:2		RATIO 1:3		RATIO 1:4		RATIO 1:5	
		Power input kW	Torque output Nm	Power input kW	Torque output Nm	Power input kW	Torque output Nm	Power input kW	Torque output Nm	Power input kW	Torque output Nm	Power input kW	Torque output Nm
BG42	2800	102.6	336	62.5	307	35.2	230	17.8	175	13.7	180	9.9	162
	2000	75.4	346	46	317	25.8	237	13	178	10	183	7.2	166
	1500	58.1	355	35.3	324	19.8	243	9.9	181	7.6	187	5.5	168.5
	1000	39.8	365	24.3	334	13.6	249	6.8	186	5.2	191	3.7	171
	800	32.5	372	19.7	339	11	253	5.5	188	4.2	193	3	173
	600	24.9	380	15	344	8.4	257	4.2	191	3.2	195	2.3	175
	400	17	390	10.3	353	5.7	261	2.8	194	2.2	198	1.5	177
	100	4.5	411	2.7	370	1.5	272	0.7	201	0.6	204	0.4	182
	50	2.3	420	1.4	376	0.75	278	0.37	203	0.25	206	0.2	184
	10	0.5	432	0.3	383	0.15	281	0.07	206	0.05	209	0.04	186
BG55	1500	125	763	88.7	813	44.4	543	20.2	370	19.5	478	15	458
	1000	86	787	60.7	835	30.6	581	13.9	382	13.3	489	10.2	467
	800	70	800	49.4	850	24.8	588	11.3	386	10.8	495	8.2	472
	600	53	810	37.7	864	18.8	576	8.5	391	8.2	501	6.3	478
	400	36.6	840	26	893	12.9	591	5.8	398	5.6	509	4.2	484
	100	9.7	893	6.9	950	3.4	618	1.5	416	1.4	529	1.1	503
	50	5	912	3.5	972	1.7	632	0.8	421	0.7	534	0.6	508
	10	1	941	0.7	1000	0.35	643	0.16	428	0.15	543	0.1	515
BG75	1500	265	1622	147	1349	109	1325	74	1363	46	1128	32	983
	1000	185	1694	102	1398	75	1368	51	1402	32	1158	22	1007
	800	151	1728	83	1421	61	1391	41	1423	28	1173	18	1018
	600	116	1770	63	1452	46	1416	32	1447	19	1190	14	1032
	400	80	1824	43	1490	32	1449	21	1475	13	1212	9	1049
	100	21	1963	11	1585	8	1532	6	1550	3	1265	2	1091
	50	11	2009	6	1617	4	1560	3	1574	2	1282	1	1104
	10	2.3	2077	1.2	1662	0.9	1597	0.6	1606	0.4	1306	0.2	1121

FACTORES DE DISEÑO Y DIMENSIONADO

En los casos en que las condiciones de aplicación sean diferentes a las descritas en el apartado anterior, se deberá aplicar un factor de corrección para determinar correctamente el tamaño del reenvío, en función de la aplicación real de trabajo.

FACTOR DE CORRECCION POR HORAS DE TRABAJO (H)

HORAS AL DIA	24	18	12	8	4	2	1
FACTOR H	1.25	1.18	1.1	1	0.9	0.8	0.7

FACTOR DE CORRECCION DE LA VIDA UTIL (L)

VIDA UTIL TEORICA (HORAS)	60.000	40.000	20.000	15.000	10.000	5.000	3.000
FACTOR L	1.3	1.15	1	0.95	0.9	0.85	0.8

FACTOR DE CARGA (C)

NUMERO DE ARRANQUES POR HORA		1	5	20	60	120	
CARGA UNIFORME		1	1	1.1	1.8	2.2	2.7
CARGA CON CHOQUES MODERADOS		1	1.4	1.8	2.2	2.7	3.2
CARGA CON CHOQUES FUERTES		1.4	1.8	2.2	2.7	3.2	3.8

EL PAR DE DISEÑO QUE NECESITAMOS DEBE SER MULTIPLICADO POR LOS FACTORES ARRIBA INDICADOS PARA OBTENER EL VALOR DE SELECCION.

MU = M x (H x L x C) MU= par de diseño M=par nominal H=factor jornada
L= factor vida C=factor arranque